

ITM A FAST AND EFFECTIVE PROBLEM SOLVER



The ITM spreader is ideal for fast action on cycle paths and foot-paths, factory sites, car parks etc.

The ITM spreaders are available in three sizes: ITM 35, 45 og 60. ITM is road-speed related and may be attached to tractors and cars with a towing bracket. By means of a special bracket it can also be connected to a fork-lift truck.

All models feature a manual clutch.

The ITM spreader is versatile and easy to manoeuvre due to a low unladen weight and low center of gravity.



ITM 35

EPOKE ITM 30 - 45 - 60

(2005-11-02.BA)

Technical data and dimensions

	ITM 35	ITM 45	ITM 60
Approx. capacity:	350 l	450 l	600 l
Spreading width:	780 mm	1010 mm	1461 mm
Track gauge:	1028 mm	1290 mm	1730 mm
Total width:	1150 mm	1435 mm	1885 mm
Self-weight:	145 kg	192 kg	220 kg

Standard equipment: Standard rubber base, spring base, spring base adjustment, delivery roller, transmission, rims and tyres

Optional equipment: Agitator, drawbar w. eye or ball bearing, three-point suspension, fitting for fork-lift truck, lights, electronic remote control and cover.

Features:

Stepless adjustment of the spreading flow. This means that the spreader can be set to deliver as little as possible but as much as necessary.

The ITM spreader may deliver sand, abrasive, urea, oil absorbers and other common spreading materials and combinations of these.

All models may be fitted with the Epoke dosing system, featuring an agitator, which prevents material bridge building and the delivery roller ensures accurate and even delivery over the entire spreading area.

Like all other Epoke machines, ITM features surface treatment consisting of sandblasting, zinc dust priming, 2-component polyurethane base coat and a 2-component top coat.

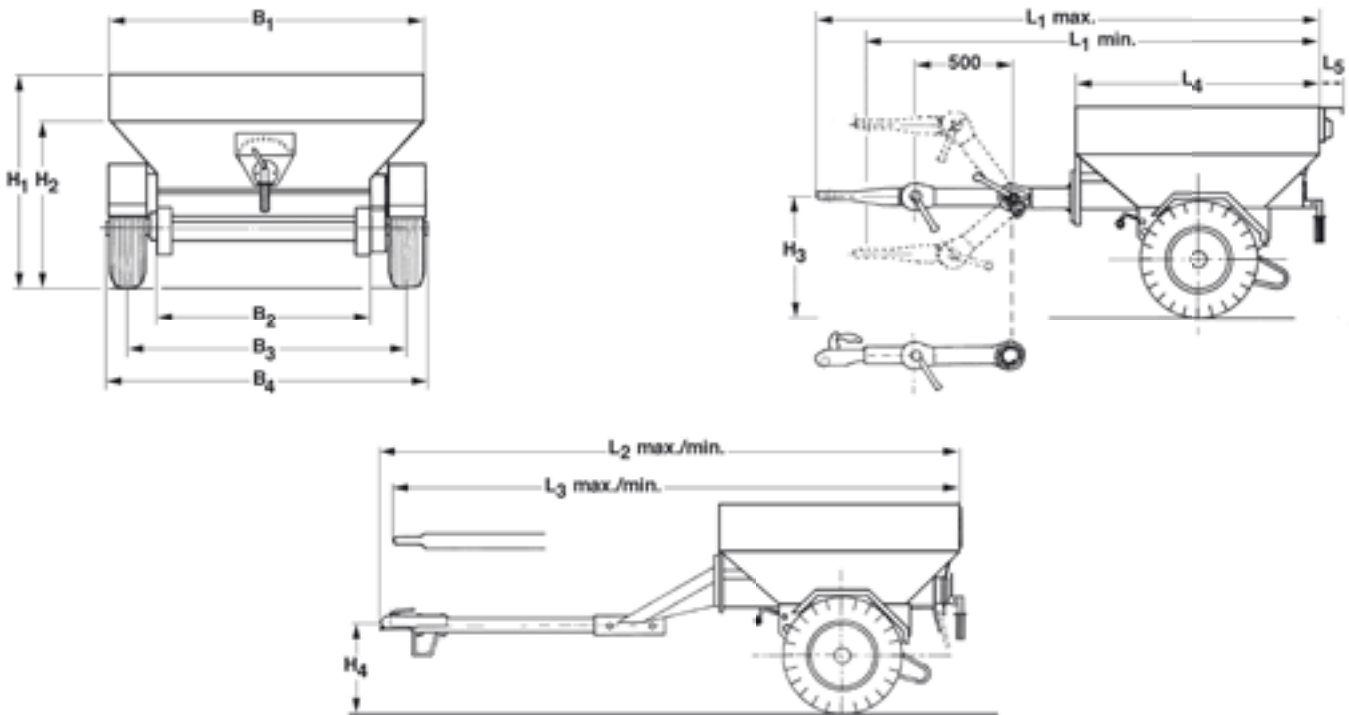

	B ₁	B ₂	B ₃	B ₄	H ₁	H ₂	H ₃		H ₄		L ₁		L ₂		L ₃		L ₄	L ₅	V-m ³
							max.	min.	max.	min.	max.	min.	max.	min.	max.	min.			
ITM35	1125	782	1028	1150	770	595	760	160	695	300	1930	1530	2000	1600	1900	1500	885	75	0,35
ITM45	1435	1012	1290	1435	840	715	880	280	825	430	1930	1530	2000	1600	1900	1500	885	75	0,45
ITM60	1885	1461	1730	1885	840	715	880	280	825	430	1930	1530	2000	1600	1900	1500	885	-	0,60



In order to maintain the high and uniform product standard Epoke® A/S has been certified by Lloyd's register to ISO 9001:2000.
TLG B-3 approval - GS approval - E1 approval
RoHS directive - WEEE directive

– de-icing of roads!

Epoke® A/S
Vejenvej 50, Askov
DK-6600 Vejen
Tel. +45 76 96 22 00
Fax +45 75 36 38 67
epoke@epoke.dk
www.epoke.dk

